



Wrong-Way Driving Detection and Prevention System: A Pilot Deployment

Corey Quinn, PE
Director of Expressway Operations
Central Florida Expressway Authority



About us

- Created as OOCEA in 1963
- Became Central Florida Expressway Authority on June 20, 2014
- Orlando metropolitan area
- CFX Operates:
 - 109-centerline miles of expressway
 - 14 mainline toll plazas
 - Over 1,100,000 daily transactions





Wrong Way Driving Statistics

- Wrong way collisions
 - 3% of crashes on high-speed divided highways
 - Fatality rate: 12-27 times higher than other types of accidents
- Nationally between 2004 and 2009:
 - 1,566 fatal wrong way crashes on limited access highways
 - 2,139 fatalities
 - Averages 260 fatal collisions nationally
 - Averages 360 fatalities per year



Wrong Way Driving Statistics



Related Factors for Drivers and Motorcycle Riders Involved in Fatal Crashes, 2011
 FARS/GES 2011 Data Summary (USDOT)

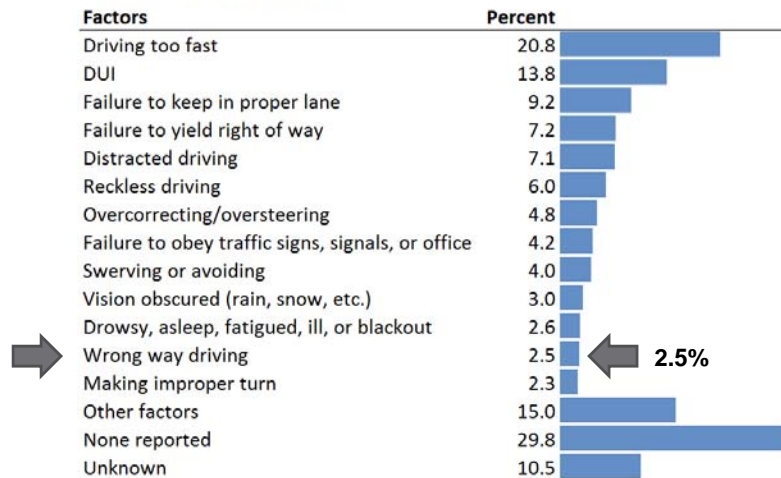

WWD Countermeasures Pilot Project

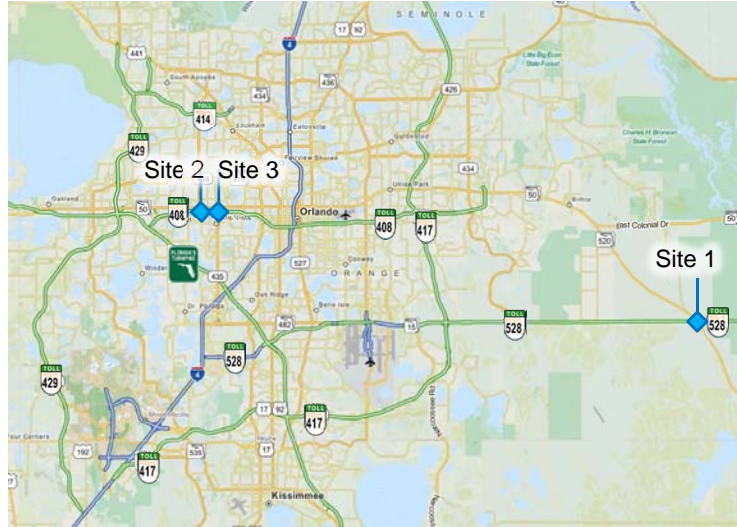

WWD Countermeasures Pilot Project

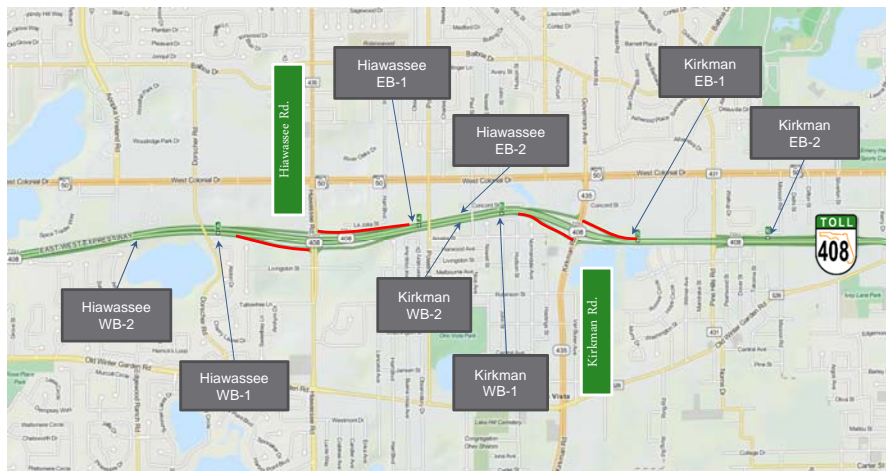

WWD Countermeasures Pilot Project

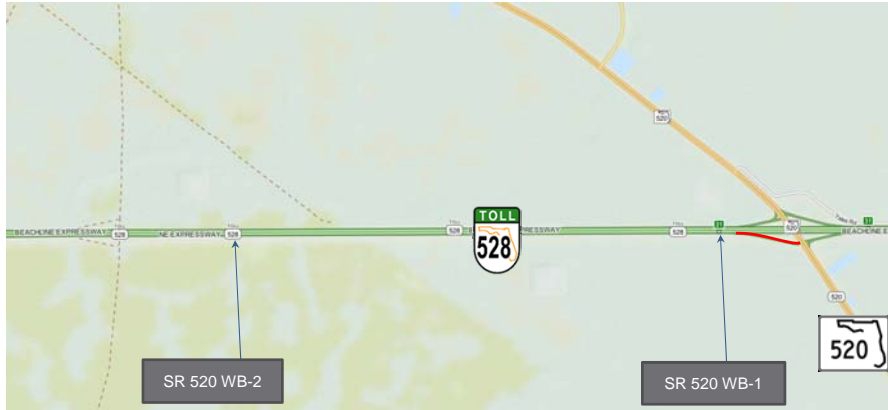

Ramp Detection Equipment

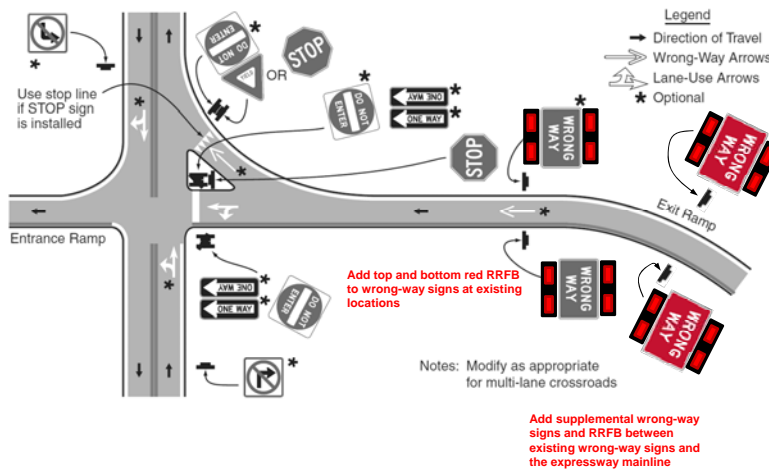



Ramp Detection Equipment

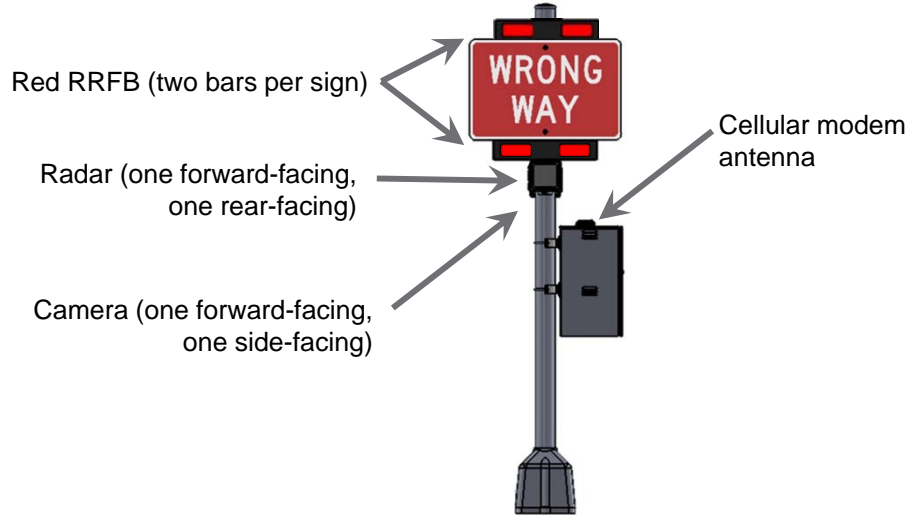

Ramp Detection Equipment

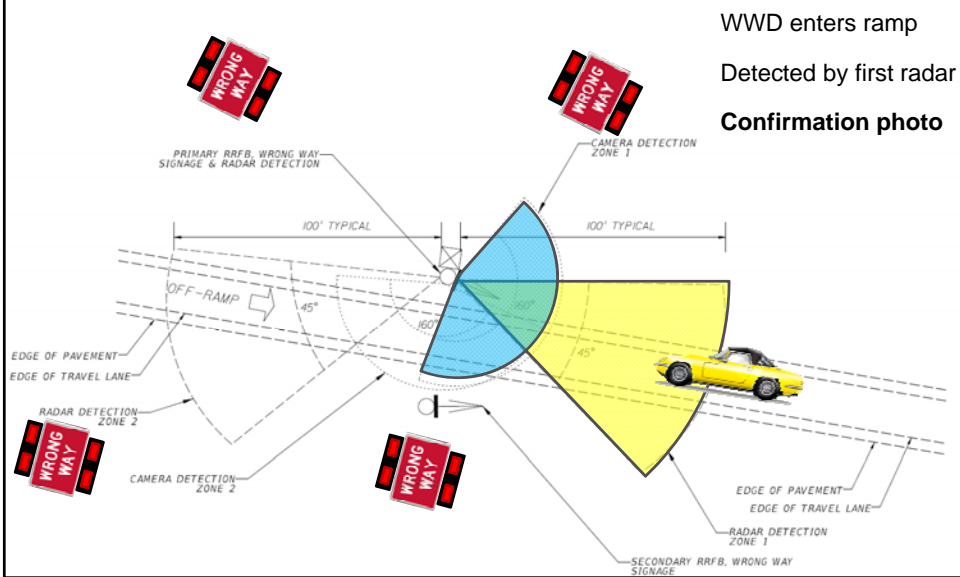

Ramp Detection Equipment

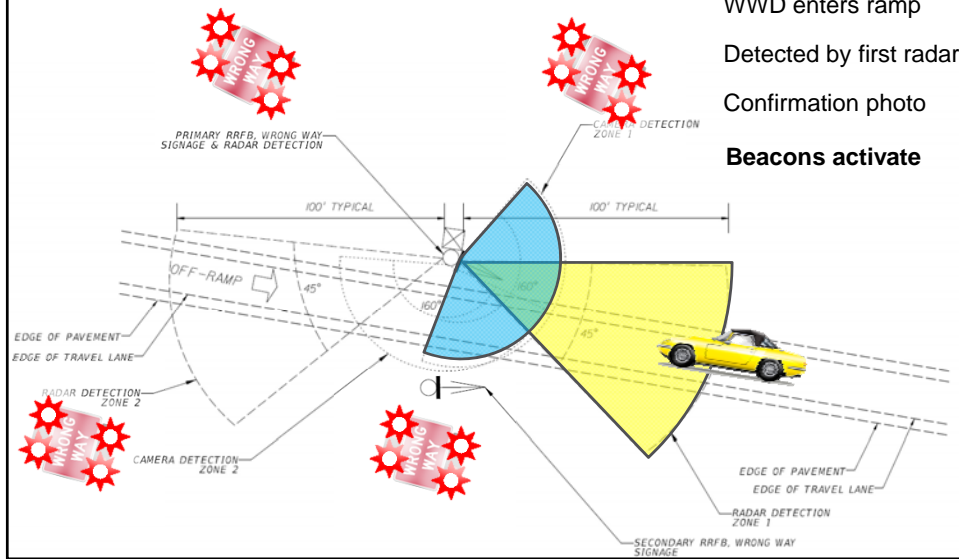

Ramp Detection Equipment

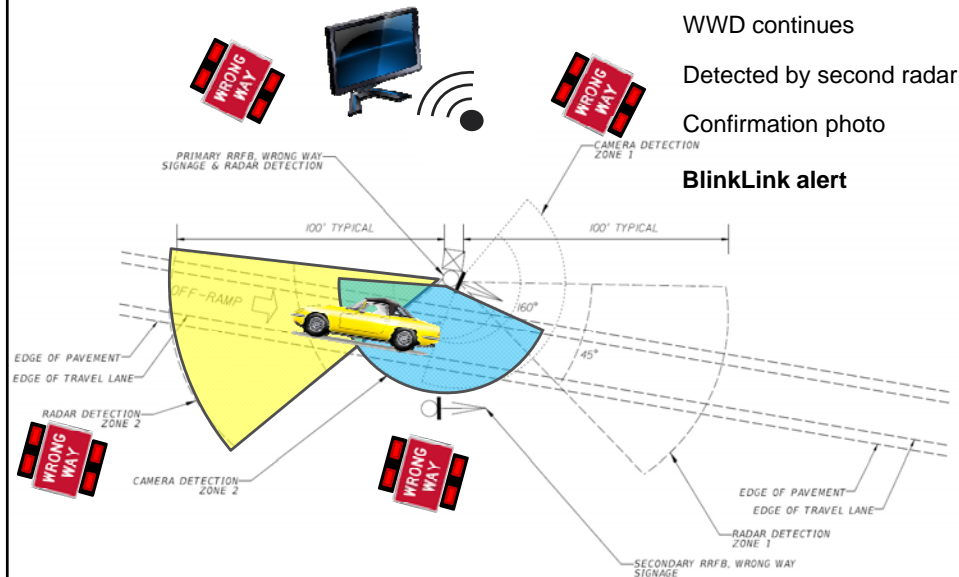



Mainline Detection Equipment

- Leveraging existing Wavetronix HD sensors on mainline
- 10 test locations to be equipped with Click 512! units to enable WWD detection
- WWD detection data to be logged with vendor software, eventual goal is to use SunGuide



Concept of Operation

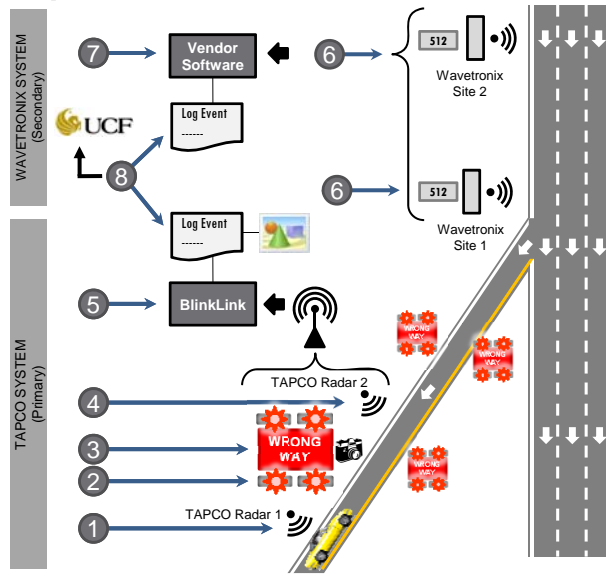



Parking Lot Testing

- Temporary parking lot test conducted to verify technology
- Tested visibility of beacons during day and night conditions
- Experimented with radar detection zones in a controlled environment



Preliminary Lessons-Learned

- Two light bars per sign (top and bottom) will be used to improve visibility of beacons.
 - Initial test only had one light bar.
- Two pair of signs will be deployed at each ramp (beacons at the remote pair slaved to the first pair).
 - Provides enhanced visibility of warning in the event the driver passes the first sign before beacon activation



Status of Project

- Design plans are complete
- Awarded: November 2014
- NTP: Targeted for Early 2015

Questions



Corey Quinn, PE
Director of Expressway Operations
Central Florida Expressway Authority
(407) 690-5000
corey.quinn@CFXWay.com